

Interoperability Working Group



Projects

- PJ31: Ethernet over OTN Technology**
- 400Gigabit Ethernet -LANPHY Transmission Technology etc...
- PJ32: Multi-Technology Transport Network Control Technology**
- Multi Layer/ Multi Domain Network Control Technology
- SDTN (Software Defined Transport Network) etc...
- PJ33: Multi-Band WDM Technology (Tentative)**

Chair : Naoaki YAMANAKA (Keio University)

Vice chairs : Hiroyuki OHNISHI (NTT)
Satoru OKAMOTO (Keio University)

Members : Keio University, NTT, KDDI Research, Anritsu, OKI, Mitsubishi Electric, NEC, NICT



Our demo movies are available on the Kei-han-na OpenLab YouTube channel.



Demonstration Concept

- ◆ **“Integration of the Heterogeneous All Optical Network and End-to-End Operation in Hybrid Cloud Era” at iPOP2023-Showcase. (PJ32)**
- ◆ **We intend to showcase network service and slice management empowered by hybrid cloud based orchestration and machine learning, including end-to-end latency-sensitive networks, distributed edge/data center networks, and open/disaggregated optical/photonic networks for beyond 5G/6G era.**

Publications

- Shinya Nakamura, Kohei Shiomoto, Hyde Sugiyama, Yusuke Hirota, Noboru Yoshikane, Kentaro Sugawara, Masatake Miyabe, Tomotaka Eguchi, Satoru Okamoto, Masaki Murakami, Takahiro Hirayama, Ikuo Sato, Thomas Roux, “First Demonstration of End-to-End Network Slicing with Transport Network Coordination and Edge Cloud Applications in 5G Era,” 24th OptoElectronics and Communications Conference/International Conference on Photonics in Switching and Computing (OECC/PSC 2019), No. PDP-4, July 2019.
- M. Shiraiwa, N. Yoshikane, S. Xu, T. Tsuritani, N. Miyata, T. Mori, M. Miyabe, T. Katagiri, S. Yoshida, M. Tanaka, T. Hayashi, H. Sugiyama, I. Satou, M. Mikuni, S. Okamoto, N. Yamanaka, B. Jeong, Y. Awaji, N. Wada, “Experimental Demonstration of Disaggregated Emergency Optical System for Quick Disaster Recovery,” IEEE/OSA Journal of Lightwave Technology (Invited), August 2018.
- M. Shiraiwa, N. Yoshikane, S. Xu, T. Tsuritani, N. Miyata, T. Mori, M. Miyabe, T. Katagiri, S. Yoshida, M. Tanaka, T. Hayashi, H. Sugiyama, I. Satou, M. Mikuni, S. Okamoto, N. Yamanaka, Y. Awaji, and N. Wada, “First Experimental Demonstration of Disaggregated Emergency Optical System for Quick Disaster Recovery,” in Proc. Optical Fiber Communication Conference (OFC2018), San Diego, CA, USA, Th2A.29, March 2018.

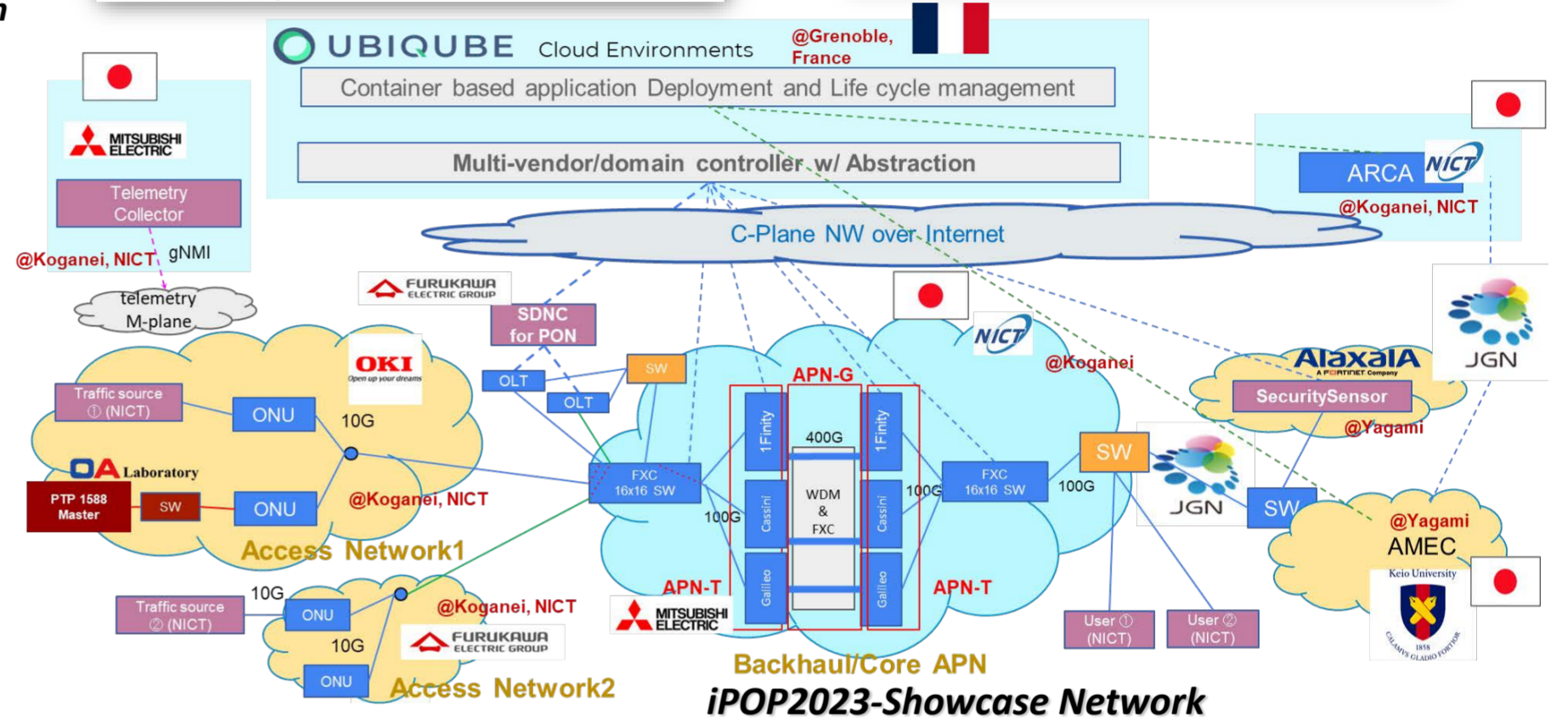
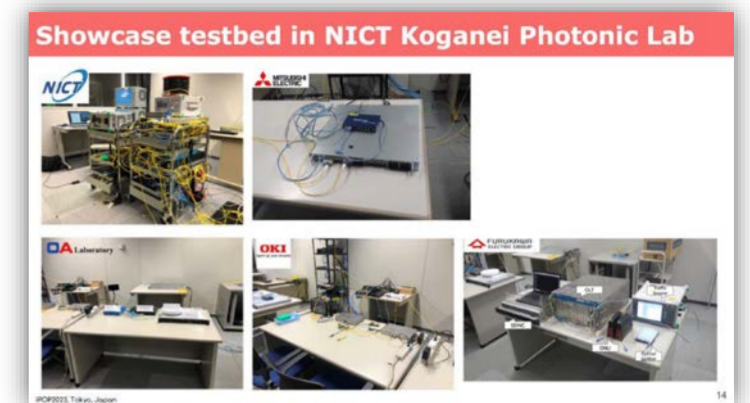
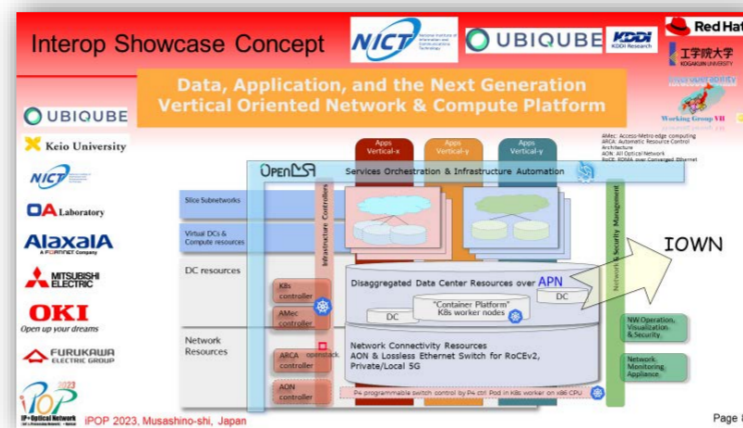

Open Optical Network (O²N) Working Group

Chair :

Takehiro Tsuritani (KDDI Research)

Vice chair :

Emmanuel Le Taillandier de Gabory (NEC)
Masayuki Kashima (OKI)

Members :

Keio University, NEC,
KDDI Research, Oki Electric, Mitsubishi Electric

What O²N WG?

- ◆ Focuses on promoting interoperability testing and standardization as de fact for realizing **“open” and “disaggregated” optical networks from backbone/metro networks to access networks.**
- ◆ Acts with collaborating **new project** of “Research and Development of Advanced Optical Transmission Technology for Green Society (JPMI00316)” **Theme II: High Capacity and High Multiplex Optical Access Network Transmission Technologies (2022-2025)** and past research project “Research and Development of Innovative Optical Network Technology for a Novel Social Infrastructure (JPMI00316)” **Theme III: High efficiency reliable optical access & metro network** funded by the Ministry of Internal Affairs and Communications.

Motivation and goal

- ◆ Open and disaggregated optical networks would be capable of **CAPEX reduction** since each network module such as transponders and optical switches can be appropriately introduced in the right place at the right time. However, it might **increase OPEX.**
- ◆ In backbone and metro networks, there are concerns that openness will increase operational costs due to the increased complexity of guaranteeing optical signal quality and device control, and the difficulty of identifying and recovering from faults. In this activity, we will promote collaboration and verification of elemental **technologies to realize optimal open optical network operations.**
- ◆ In the access network, openness/virtualization is being considered, but since it’s a stand-alone control, it’s necessary to efficiently control the whole backbone, metro, and access networks. This activity will verify and promote elemental **technologies for efficient end-to-end network control.**

Developments and demonstration

Key architecture E2E NW management: bandwidth/route optimization

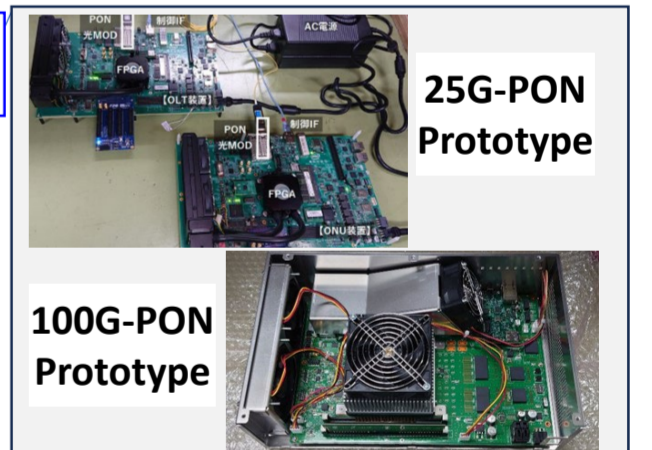
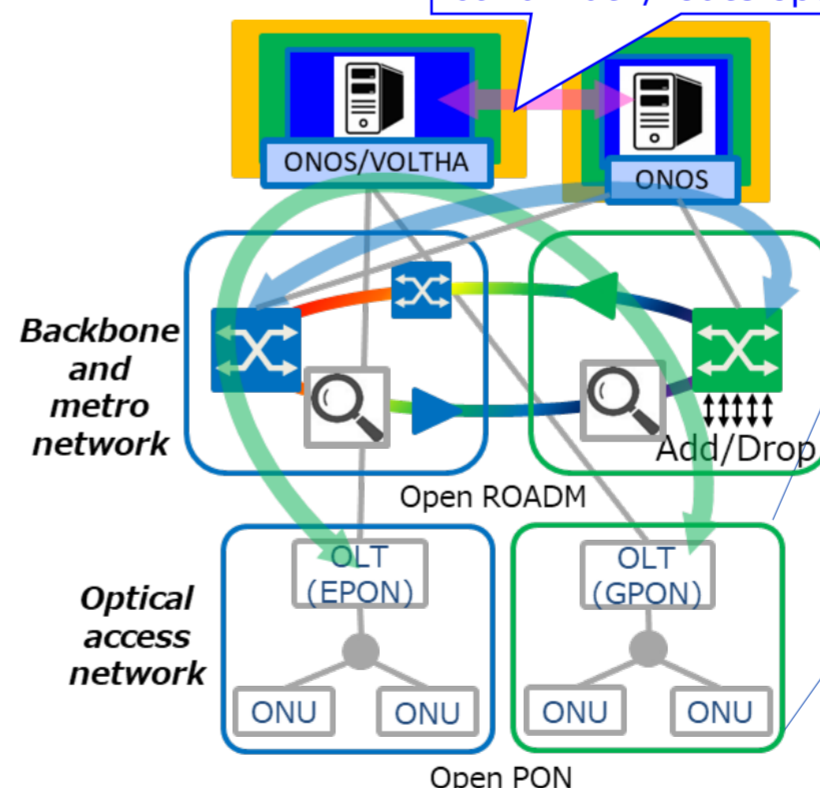

25G/100G testing machine for access optical NW



You can watch the demo movie on Kei-han-na OpenLab YouTube channel.

